

**Document Number**    **Revision**  
APN-0006                A

**Prepared By**  
NGB

**Approved By**  
NB

**Title**  
Powering an External Sensor from a 4-20mA Source.

**Page**  
1 of 7

## POWERING AN EXTERNAL SENSOR FROM A 4-20MA SOURCE

### Introduction

In some applications where the ORB is powered from solar or from batteries or where the power to the ORB is intermittent, it may be advantageous to power external sensors from the ORB and not from the external power source. In other applications, it is important that the voltage applied to an external sensor be known and constant and in cases where the external supply may vary, powering the sensor from a reliably voltage would be an advantage.

The ORB has the ability to power external sensors using the two current sources. The voltage produced by the current sources is known and is constant even when the ORB has no external power. Furthermore, the current sources can be controlled to only power on for the duration of a measurement in order to save on power.

The Sensor being used in this application is a linear position sensor as shown in Figure 1. The sensor is provided with power and ground and outputs a voltage that represents the position of the sensor. Internal to the sensor is a linear potentiometer where the wiper moves in response to the extension of the sensor arm. The voltage present on the wiper will be measured using one of the ORB's voltage inputs.



Figure 1 - Linear Position Sensor

**Document Number**    **Revision**  
 APN-0006                A

**Prepared By**  
 NGB

**Approved By**  
 NB

**Title**  
 Powering an External Sensor from a 4-20mA Source.

**Page**  
 2 of 7

## Hardware Interconnect

The ORB-X1 has two integrated current sources that can be used to drive 4-20mA sensors. The current supplied by each source is accurately measured and reported. The current sources on the ORB generate their own 12V source, meaning that the supply to the ORB is not critical. With an input voltage between 9V to 75V or with AA batteries or solar, the ORB will generate 12V on the current sources. Note that with AA batteries, the measurement interval should be long to avoid draining the batteries.

Pins 1 and 2 of the ORB should be connected to power and ground. The power in this case is likely to be derived from a solar panel. If solar is used, measurements can continue to be taken outside of sunlight hours as the ORB has an internal backup battery. It is recommended that a 1A fuse be inserted between the solar panel and the power connection of the ORB. The fuse protects the battery in the event that the ORB fails or the positive wire comes loose. A 10W solar panel will ensure that the internal backup battery remains charged even during extended periods of cloud.

Since the ORB has two current sources, it can power two linear position sensors. In this case, a single linear position sensor is used and it is decided to connect it to Source 1 on pin 3. From the linear position sensor datasheet, we see that the sensor has three wires, blue, yellow and brown. Blue and brown are connected to the ends of the potentiometer and yellow is the wiper. Since the sensor is to be powered by the ORB, blue and brown need to be connected to a source on the ORB and ground. The output from the wiper will be measured using a voltage input on the ORB; in this case, IN1 is chosen on pin 8.

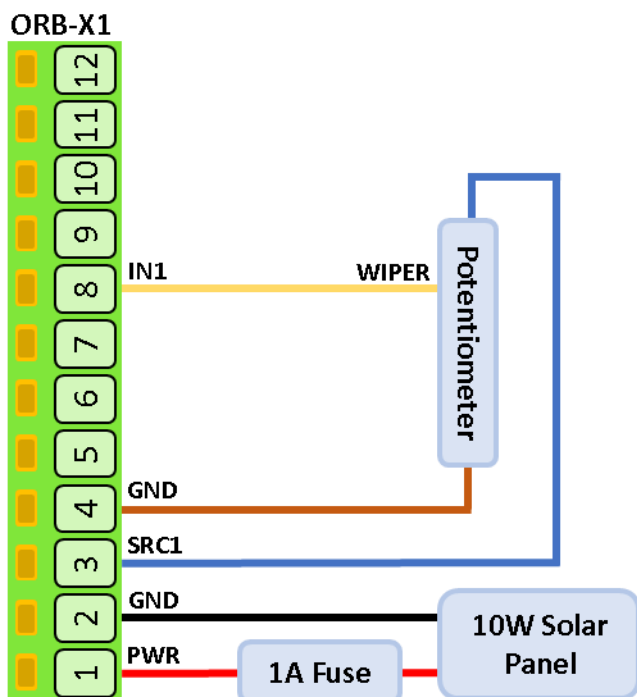

Figure 2 - Potentiometer Wiring Diagram

**Document Number**    **Revision**  
APN-0006                A

**Prepared By**  
NGB

**Approved By**  
NB

---

**Title**  
Powering an External Sensor from a 4-20mA Source.

**Page**  
3 of 7

## ORB Configuration

If you are configuring the ORB for the first time, use a phone, tablet or laptop to access the ORB's integrated webserver. To activate the webserver, press the setup key on the ORB for 2 seconds and then connect to the ORB's Wi-Fi on your phone, tablet or laptop. Passwords for the ORB's Wi-Fi and webserver can be found on a tear-off sticker under the lid of the ORB. For further details on how to access the webserver, please see the "ORB-X1 User Guide". If the ORB is already available on the Senquip Portal, simply login to the Portal and make the required changes remotely.

In this application, it is assumed that the ORB is powered via solar. To conserve energy, the rate of transmission is set to 10 minutes. The ORB can be set to transmit via either Wi-Fi or GSM. The configuration of the transmission is not covered in this application note.

Note that only settings used in connecting the ORB to the linear position sensor are discussed in this application note.

## General Setup

For general setup, use the **General** tab on the ORB webserver as shown in Figure 3. Remember to save when complete.

1. Give the ORB a name that is meaningful to the user, in this case, "Steering Position."
2. To save energy, the ORB is set to wake up every 10 minutes (600 seconds), report the position and then return to sleep.
3. Set the Transmit Interval to 1 so that the position is sent each time it is measured.
4. There are no warnings or alarms used in this application that require faster updates be sent and so the Exception Interval is set to be the same as the transit interval. Note that if alerts are more important than actual levels, that the transmit interval could be set to only transmit say once a day. The ORB would wake every 10 minutes, check the levels and only transmit if there was a warning or alarm. Power would be saved in this way. If the Exception Interval was set to 1, then the ORB would transmit on every measurement whilst a warning or alarm was current.
5. The *Device Always On* and *Web Server Always On* options are both not ticked in order to save power.
6. If AA batteries are being used as a backup to power the ORB, then an alert should be set for when the batteries are low.

**General**

Device ID	<input type="text" value="KV89DLBK2"/>
Device Model	<input type="text" value="ORB-X1-G"/>
Firmware Version	<input type="text" value="2020011309"/>
Hardware Revision	<input type="text" value="2"/>
Device Name	<input style="border: 2px solid green; border-radius: 5px; padding: 2px 5px;" type="text" value="Steering Position"/> ✓
Base Interval	<input style="border: 2px solid green; border-radius: 5px; padding: 2px 5px;" type="text" value="600"/> ✓ <input type="text" value="Seconds"/>
Transmit Interval	<input style="border: 2px solid green; border-radius: 5px; padding: 2px 5px;" type="text" value="1"/> ✓
Exception Interval	<input style="border: 2px solid green; border-radius: 5px; padding: 2px 5px;" type="text" value="1"/> ✓
Device Always On	<input type="checkbox"/> Enabled
Batch Transmit	<input checked="" type="checkbox"/> Enabled
Web Server	<input type="checkbox"/> Enabled
<b>Power Input</b>	
Power Loss Alert	<input checked="" type="checkbox"/> Enabled
Hibernate on Power Loss	<input checked="" type="checkbox"/> Enabled
Hibernate Delay Intervals	<input type="text" value="5"/>
Count Hours	<input type="checkbox"/> Enabled
<b>AA Battery</b>	
AA Battery Low Alert	<input checked="" type="checkbox"/> Enabled
Threshold	<input type="text" value="4.8"/> Volts

**Figure 3 - General Setup**

### Current Source 1 Setup

The position sensor is powered by the ORB’s Source 1 on Current Loop 1. For current loop setup, use the **External** tab on the ORB webpage or Senquip Portal and select the Current Loop 1 peripheral as shown in Figure 4.

1. Give the current data a meaningful name; in this case “Linear Position Power”.
2. Position data is to be sent every time the ORB wakes up and so the Interval is set to 1.
3. Use the Start Time setting to apply power to the sensor a short time before the measurement is taken. This allows the sensor data to stabilise before a measurement is taken. Make this value as short as possible to save energy when operating off solar or AA batteries.
4. Since in this application, we are only using the current loop to power the external sensor, the rest of the settings do not matter.
5. The current measured by the Current Loop peripheral could be used to check that the sensor was still connected and if not an alarm could be sent. In this example, warnings and alarms are not enabled.

### Current Loop 1

A name for the input that is meaningful to the user.

Name	1	Linear Position Power	✓
Interval	2	1	✓
Always On	<input type="checkbox"/> Enabled		
Start Time	3	1	✓
Seconds			
<b>Calibration</b>			
Low In	4	0	
High In		100	
Low Out		0	
High Out		100	
Unit		mA	
<b>Warning</b>			
Warning	5	<input type="checkbox"/> Enabled	
<b>Alarm</b>			
Alarm		<input type="checkbox"/> Enabled	
Alarm/Warning Hysteresis		1	

**Figure 4 - Current Source Setup**

## Input 1 Setup

The voltage representing the position of the wiper is measured with Input 1. For Input 1 setup, use the **External** tab on the ORB webpage or Senquip Portal and select the Input 1 peripheral.

1. Give the current data a meaningful name; in this case “Linear Position”.
2. Position data is to be sent every time the ORB wakes up and so the Interval is set to 1.
3. Select the Analog option as Input 1 is going to be used to measure a voltage value.
4. From the sensor datasheet, we see that 0V represents 0mm extension and full voltage represents 100mm. Calibration is used to convert the supplied 12V to represent to 100mm.
5. No warnings or alarms are used in this application.

**Document Number**    **Revision**  
 APN-0006                A

**Prepared By**  
 NGB

**Approved By**  
 NB

**Title**  
 Powering an External Sensor from a 4-20mA Source.

**Page**  
 6 of 7

### Input 1

Name	1	Linear Position	✓
Interval	2	1	✓
Mode	3	<input checked="" type="radio"/> Analog <input type="radio"/> Digital <input type="radio"/> Frequency <input type="radio"/> Duty Cycle	
<b>Digital</b>			
Digital Threshold		6	Volts
Digital Hysteresis		1	Volts
Count Hours		<input type="checkbox"/> Enabled	
Digital Change Alert		<input type="checkbox"/> Enabled	
<b>Calibration</b>			
Low In	4	0	✓
High In		12	✓
Low Out		0	✓
High Out		100	✓
Unit		mm	✓

Figure 5 - Input 1 Setup

## Access to the Linear Position Data

The linear position data that is being sent by the ORB can be viewed in various ways:

- 1) Login the ORB's webserver on your local network and view the real-time serial data being sent. In this application, we disabled the webserver to conserve power but it could be enabled if required.
- 2) Login to the Senquip Portal ([portal.senquip.com](http://portal.senquip.com)) and view the real-time position data or alternately view or download the data from the table view under "Raw Data".

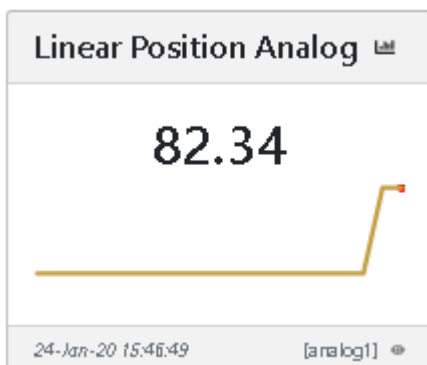

- 3) Configure the ORB to send the data to a UDP, HTTP or MQTT server. In this case, the data will arrive on the remote server in in JSON format.

**Document Number**    **Revision**  
APN-0006                A

**Prepared By**  
NGB

**Approved By**  
NB

---

**Title**  
Powering an External Sensor from a 4-20mA Source.

**Page**  
7 of 7

## Conclusion

The physical connection and setup required to connect a linear position sensor to the ORB is quick and simple. Once connected, the position data provided by the linear position sensor can be viewed anywhere in the world on the internet or on a company server.